

+ HEATING
FOR PELLETS:

PURO WIN PELLETS



16 TO 100 KW

APARTMENT BUILDINGS,
COMMERCIAL PROPERTIES



JUST LIKE NATURE:
**ALWAYS ONE
STEP AHEAD.**



YOUR SPECIALIST FOR INNOVATIVE HEATING SOLUTIONS

WITH THE ENERGY OF TOMORROW

The Austrian family-owned company Windhager has stood for high-quality heating appliances and reliable service for over 100 years. Our many innovative technologies have had a profound impact on the market in the past and we remain committed to continuously improving the power, efficiency and sustainability of our products. Our pellet, wood and wood shaving boilers as well as our gas heating systems and heat pumps already meet the highest quality and environmental standards of tomorrow today. We will be consistently expanding our leading edge so that you can continue to enjoy sustainable heat with your Windhager heating system in the future – permanently, cost-efficiently and comfortably.

OVERVIEW

Pellets - Environmental protection at the push of a button	4	TECHNICAL DATA.....	8 – 9
The Windhager subsidy service.....	5	PuroWIN pellets - 60.....	8
		PuroWIN pellets - 75 – 100.....	9
WINDHAGER PUROWIN PELLETS	6	THE WINDHAGER PRINCIPLES	10
PuroWIN pellets.....	6		
PELLET STORAGE	7 – 8		
Pellet storage solution	7		
PuroWIN pellets cascade	7		
App-based storage planning	8		

PELLETS

ENVIRONMENTAL PROTECTION AT THE PUSH OF A BUTTON

When you choose a Windhager pellet heating system, you are deciding for sustainable fuel with a future. This is because pellets are made exclusively of natural wood that is ground without any additives and pressed using high pressure into standardised cylindrical rolls. Only about 1% of the amount of energy contained in the fuel is needed during production, making pellets the fuel with the best energy balance.

PELLETS ARE
CLIMATE NEUTRAL
AND CO₂ TAX FREE



When the pellets are burning in the boiler, only as much CO₂ is released as the tree was able to store from the air while it was growing. That is why pellets are a CO₂ neutral fuel and the guaranteed right choice for anyone who wants to heat their home in an environmentally friendly, safe and economical way.

MAKE SURE THEY ARE GOOD-QUALITY PELLETS

The better the pellet quality, the cleaner the combustion and better the heating power. For that reason, please be sure to only order pellets that comply with the quality regulations of EN ISO 17225-2 A1.

You can recognise high-quality pellets by the following:

- **Glossy and smooth surface**
- **Uniform pellet size**
- **Less dust**
- **Quick quality test: Throw the wood pellets into a glass of water. Good quality pellets will instantly sink to the bottom.**

USE OUR FREE SUBSIDY SERVICE

With a Windhager pellet heater, you be actively contributing to protecting the climate. There are currently very attractive subsidies for this, which vary depending on the country and region. You can get an overview of the subsidies that you may qualify for with your new pellets heating system as well as a general understanding of the topics of building, modernisation and renewable energy with our free subsidy service on the Internet at www.windhager.com



OUR PUROWIN PELLET BOILER

PRODUCED IN AUSTRIA,
SUCCESSFUL WORLDWIDE



High efficiency through
automatic cleaning tech-
nology during operation

Lowest dust emissions due
to patented gasification
boiler technology

Independent ember
retention saves
ignition energy

The ash removal
plates ensure
uninterrupted,
smooth operation

PELLET STORAGE SOLUTION

Reliable due to integrated probe monitoring: With eight-probe suction monitoring, you not only have a very flexible solution but also a reliable one. As you can position the probes anywhere, it fits into every kind of storage room. You can even store the pellets in two rooms. The intelligent probe monitoring allows for unrestricted suction power.

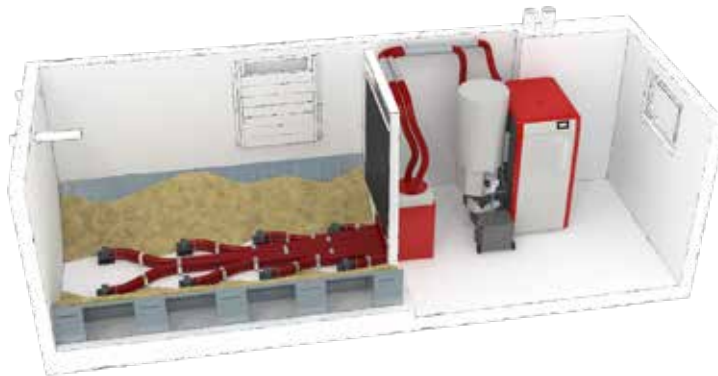

PUROWIN PELLETS CASCADE

EXCELLENT OUTPUT WITH PELLETS

The BioWIN2 can be connected to form a two or three unit cascade, thereby covering a heat demand of 400 kW.

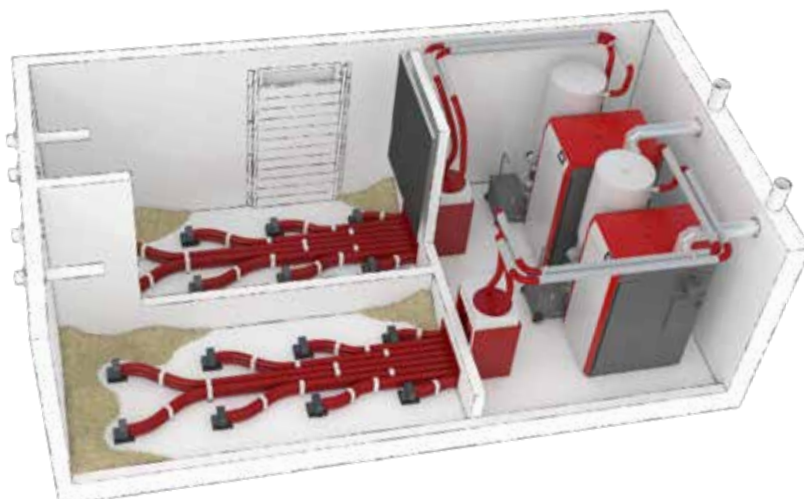



MYCOMFORT - APP THE WINDHAGER CONTROL APP

SIMPLE

- Straightforward user interface
- Easy handling, also suitable for less experienced smartphone and tablet users
- Intuitive touch and swipe operation

MOBILE

- Change temperatures and operating modes and set heating programmes from anywhere

INNOVATIVE

- New and user-friendly displays
- High resolution graphics
- Fastest responses in real time

SAFE

- Communication via the most secure connection type to date, which is above the eBanking standard



PUROWIN PELLETS 60

All measurements in mm. Minimum room height: 2100 mm

View from above:

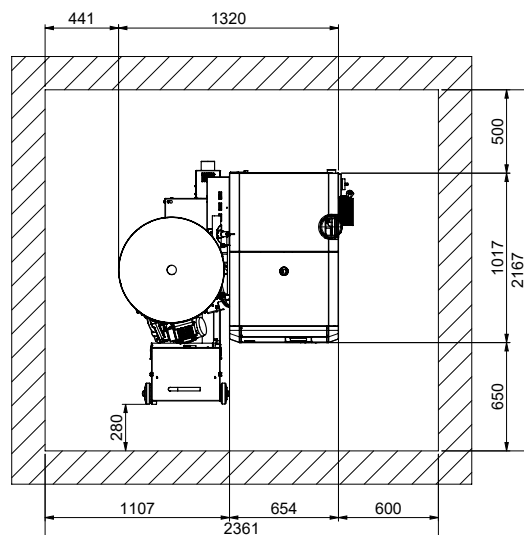

Front view:

L.....installation dimensions

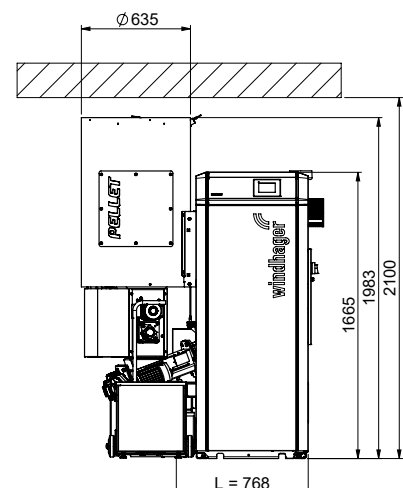

TECHNICAL DATA

PuroWIN Pellets		PWPE 60	PWPE 75	PWPE 90	PWPE 100
Nominal thermal output	kW	18–60	22–75	27–90	30–100
Efficiency at nominal load	%	94,7	94,3	93,8	93,5
Container capacity	kg	150			
Boiler body with crate (WxDxH)	mm	780 x 975 x 1795	920 x 1065 x 1850		
Installation dimensions, boiler body (WxDxH)	mm	720 x 975 x 1630	890 x 1050 x 1710		
Installation dimensions, fuel hopper suction feed system (WxDxH)	mm	675 x 770 x 1410			
Weight of boiler body	kg	562	881		
Flue gas connection diameter	mm	130	180		
Flue gas connection diameter	W	57	75	94	107
Electrical consumption (partial load/nominal load)		A+			

KV Boiler feed (Rp 5/4")
 KR Boiler return (Rp 5/4")
 AO Top flue gas pipe (Ø 130 mm)
 AH Rear flue gas pipe (Ø 130 mm)
 E Discharge (Rp 1/2")

A Fuel feed system
 (Ø 50 mm)
 B Fuel feed return air flow
 (Ø 50 mm)
 EA Electrical connections

PUROWIN PELLETS 75-100

All measurements in mm. Minimum room height: 2100 mm

View from above:

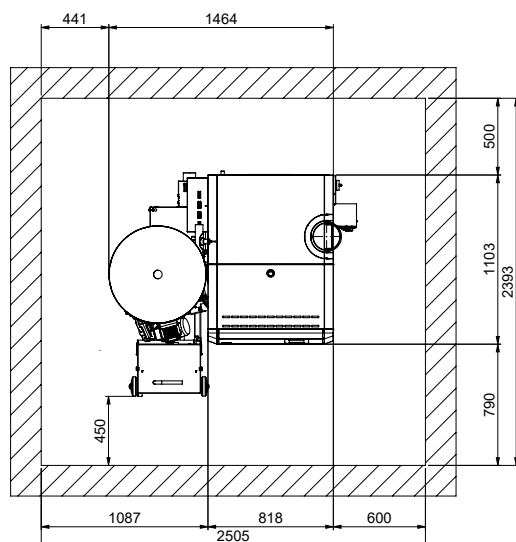

Front view:

L.....installation dimensions

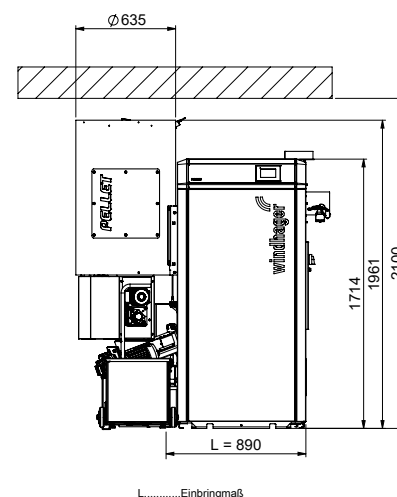

OUR WINDHAGER PRINCIPLES

Accurate advice from our expert PARTNERS

Do you have question about our products? Our competence PARTNERS are experienced heating specialists who work closely with us, guaranteeing you the best possible service.

Quick and professional customer service

The heating professionals in our extensive customer service network provide you with fast, competent and solution-oriented support – day in and day out, all year round.



EXPERIENCE ENERGY UP CLOSE: **IN THE WORLD OF WINDHAGER**

Marvel – play – try out, our spectacular experience and exhibition world the World of Windhager in Seekirchen offers 22 stations for you to discover the power of fire and innovative heating solutions up close. An exciting experience with the energy of tomorrow – for the whole family.

Read more at www.worldofwindhager.com

AVAILABLE FOR YOU EVERYWHERE



AUSTRIA

Windhager Zentralheizung GmbH
Anton-Windhager-Straße 20
A-5201 Seekirchen bei Salzburg
T +43 6212 2341 0
F +43 6212 4228
info@at.windhager.com

Windhager Zentralheizung GmbH
Carlberggasse 39
A-1230 Wien

UNITED KINGDOM

Windhager UK Ltd
Tormarton Road
Marshfield
South Gloucestershire, SN14 8SR
T +44 1225 8922 11
info@windhager.co.uk

GERMANY

Windhager Zentralheizung GmbH
Daimlerstraße 9
D-86368 Gersthofen
T +49 821 21860 0
F +49 821 21860 290
info@de.windhager.com

Windhager Zentralheizung GmbH
Gewerbepark 18
D-49143 Bissendorf

ITALY

Windhager Italy S.R.L.
Via Vital 98c
I-31015 Conegliano (TV)
T +39 0438 1799080
info@windhageritaly.it

SWITZERLAND

Windhager Zentralheizung Schweiz AG
Industriestrasse 13
CH-6203 Sempach-Station bei Luzern
T +41 4146 9469 0
F +41 4146 9469 9
info@ch.windhager.com

Windhager Zentralheizung Schweiz AG
Rue des Champs Lovats 23
CH-1400 Yverdon-les-Bains

Windhager Zentralheizung Schweiz AG
Bahnhofstrasse 24
CH-3114 Wichtrach

FOR OTHER COUNTRIES AND CONTACT OPTIONS

See windhager.com



Your expert PARTNER

PUBLICATION DETAILS

Media owner, issuer and publisher: Windhager Zentralheizung GmbH, Anton-Windhager-Straße 20, 5201 Seekirchen am Wallersee, Austria, T +43 6212 2341 0, F +43 6212 4228, info@at.windhager.com, images: Windhager; subject to amendments, printing and layout errors. 03/2022, 36511/00

windhager.com

