

The expert for oil.



EcoWIN and JetWIN – Clever heating with oil.

EcoWIN – Oil-fired unit with
condensing technology

Performance range 15 to 30.4 kW
For low-sulphur heating oil, extra light
(max. 50 ppm sulphur content).

JetWIN – Oil-fired unit with
pressure atomisation technology

Performance range 13.6 to 55 kW



Technical perfection with innovative design.

The latest oil heating comfort.

Are you looking for a reliable heating system which does not cause undue harm to the environment? Are you looking for optimised fuel consumption and ease of operation? The EcoWIN and JetWIN oil units offer you high-quality oil heating solutions which make long service life and retention of value a priority by using fuel in the most efficient way possible and applying the latest heating technology. Visible progress which is also evident from the outside, thanks to the new, unique WINDHAGER design.

● Trailblazing technology:

Behind their attractive exterior, the EcoWIN and JetWIN accommodate the very latest in pressure atomisation technology. The robust design of the Optimo burner, specially developed by WINDHAGER ZENTRALHEIZUNG, ensures particularly reliable and environmentally friendly operation.

● Outstanding ease of use:

Simply switch the boiler on – that's it! The EcoWIN and JetWIN deliver heat at the touch of a button. Once the unit is operating, InfoWIN, the unique service and operating module, keeps you informed about all important data and operating states of your boiler. With this system, ease of use reaches new heights. Queries can be dealt with simply and quickly.

● Guaranteed top quality:

EcoWIN and JetWIN units are produced according to the most stringent quality criteria in our ISO 9001 certified production plant, and are then subjected to a wide range of tests. High-quality materials such as stainless steel ensure that the units achieve a long service life. The best indication of the high quality of our boilers comes in the form of our unique, 5-year full guarantee.



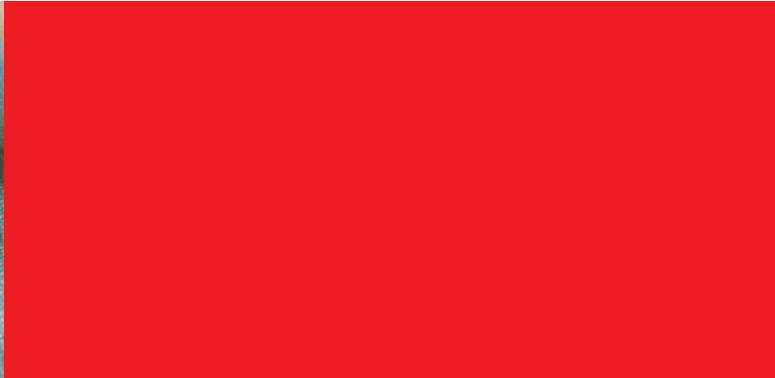

JetWIN – efficient and robust.

Heating with JetWIN is a clever decision in all ways. Here, decades of experience in pressure atomisation technology has been brought to perfection. The result is a particularly robust and efficient oil heating solution.



- **Efficient thanks to optimised burner technology.**

The individual adjustment of the oil and air quantity, and the wide range of units on offer (16 units between 13 and 55 kW) allow the boiler capacity to be easily adapted to individual heating requirements. This results in a considerable reduction in the energy-intensive switching-on and -off phases, and an increase in annual efficiency. With JetWIN, you can make savings of up to 30% in heating costs compared with older boilers.



- **A clean solution with a future.**

Optimised air / oil mixing allows the Optimo burner to achieve a considerable reduction in NO_x emissions and thus make a valuable contribution to protecting our environment. The use of low-sulphur EL heating oil also reduces sulphur dioxide emissions to a minimum.



- **Exklusiv, Premium, Klassik – three quality ranges.**

Three quality ranges enable you to choose between the particularly high-quality low-temperature units made of chrome-molybdenum-titanium stainless steel – the JetWIN “Exklusiv” and the JetWIN “Premium”, and the low-temperature unit, the JetWIN “Klassik” made of special steel.



- **Robust, with a long service life.**

Particularly when you are heating at low temperatures, condensation can develop which may lead to corrosion in the boiler. The Premium and Exklusiv JetWIN units have a rustproof boiler body made of stainless steel, and offer long-lasting corrosion protection. That is why Windhager also offers a 10-year boiler guarantee in addition to the 5-year full guarantee.

Good – better – EcoWIN.

EcoWIN condensing unit – clean and efficient.

We give top priority to an uncompromising focus on the needs of the customer while developing our products. EcoWIN oil condensing units have been adapted as far as possible to the demands of the market for the latest oil central heating systems, and cannot fail to impress on all levels:

- Particularly efficient thanks to the oil condensing technology with up to 103 % efficiency degree.
- Top combustion cleanliness thanks to blue burner technology and low-sulphur heating oil, extra light.
- Simple and clear operation with the InfoWIN operating unit and MES regulation system.
- Three different capacity levels (15, 20 and 28 kW) for all heating needs.
- Also very well suited to modernising work. The low flue gas temperatures make it possible to use a low-cost synthetic flue gas system.
- Practical, space-saving combinations with solid fuel boiler FKU or combined AKK or AKP indirect coil heating tank.
- Robust, with a long service life. Full five-year guarantee and 10-year material guarantee on the boiler body and flue gas stainless steel heat exchanger.

For the good of the environment.



EcoWIN condensing units are solely designed for operation with low-sulphur EL heating oil (max. 50 ppm sulphur content). This offers significant advantages over standard EL heating oil:

- Combustion is as clean as gas heating – reduction in sulphur-dioxide emissions by 95 %.
- Less combustion residue ensures higher operational safety and consistently high boiler efficiency.
- Usually, no neutralisation unit is required, as the condensation created is almost neutral, and not a cause for concern.



Increased heat production thanks to condensing.

Heating with oil is particularly convenient, simple and above all, safe. With the EcoWIN oil condensing units, WINDHAGER ZENTRALHEIZUNG has made these good qualities even better. The use of the latest oil condensing technology ensures first-class heating comfort and a level of energy use of up to 103 %.

During the combustion of oil, hot flue gases are created which escape unused through the chimney with standard oil boilers. By contrast, the EcoWIN uses these gases as an additional sources of energy. Using a heat exchanger, it draws energy from the flue gases and feeds it back into the system. In this way, it makes unique use of the fuel. It also does this over a long period of time, since both the EcoWIN boiler body and the heat exchanger are made of high alloy stainless steel, and are therefore particularly robust, with a long service life.

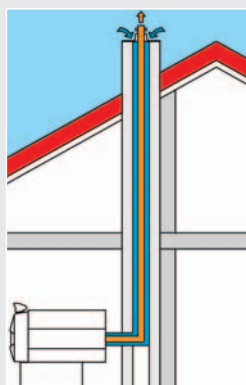
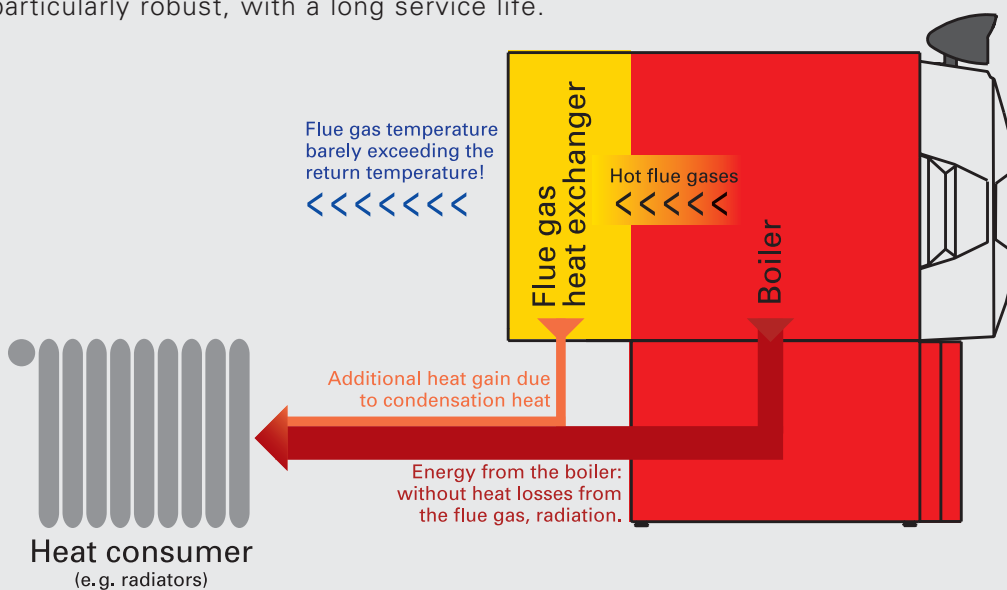

Modernising made easy.

Since particularly low flue gas temperatures are created when you heat with the EcoWIN, it is possible to use a synthetic flue gas system. The cost is significantly lower compared to modernising chimneys.

A further advantage is that the use of the synthetic flue gas system means that the EcoWIN can also be operated independently of the surrounding air in the room.

The individual solution for every need.

Everything under control.

In addition to choosing the right JetWIN oil-fired unit, the control system is an essential component of a customised heating solution. It has a decisive effect on the ease of operation, the room temperature and the oil consumption.

The measure of all things: the MES Modular Energy System.

MES manages and optimises heat production and distribution matched precisely to requirements. Its modular design ensures that the heating system can be expanded at any time. A second boiler and additional heating circuits can be subsequently installed simply, saving both time and costs.

REG standard control units.

A high level of control and ease of use for a heating and water-heater circuit is offered by the REG standard control units. These setpoint regulators can be used tied to outside or to room temperature. Subsequent expansion of the heating circuit or additional combinations are not possible.



Digital MES user module



Analogue MES user module



REG analogue user module

Smart combined solutions.



EcoWIN/JetWIN
JetWIN on FKU.

Both the EcoWIN and the JetWIN are available as particularly practical, space-saving combinations, each with the AquaWIN Kombi hot water tank or the FKU solid fuel boiler.



EcoWIN/JetWIN
combination on
AquaWIN Kombi
AKK/AKP

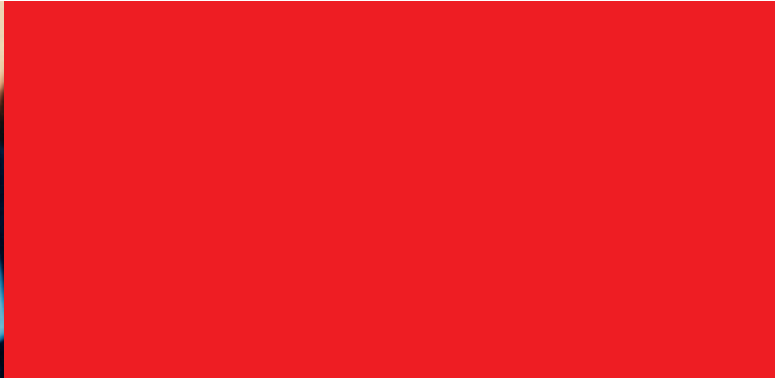

Systematic warmth.

“Every chain is only as strong as its weakest member”. That’s why the systematic thinking at Windhager Zentralheizung plays such an important role. All components and individual elements are perfectly tuned to each other, guaranteeing excellent efficiency, environmentally friendly operation and maximum heating comfort. That’s why the EcoWIN and JetWIN are excellently suited for combination with other heat generators, such as a wood or solar heating system. And all this with reassuring back-up from the experts, since Windhager Zentralheizung offers a unique function guarantee on all systems.

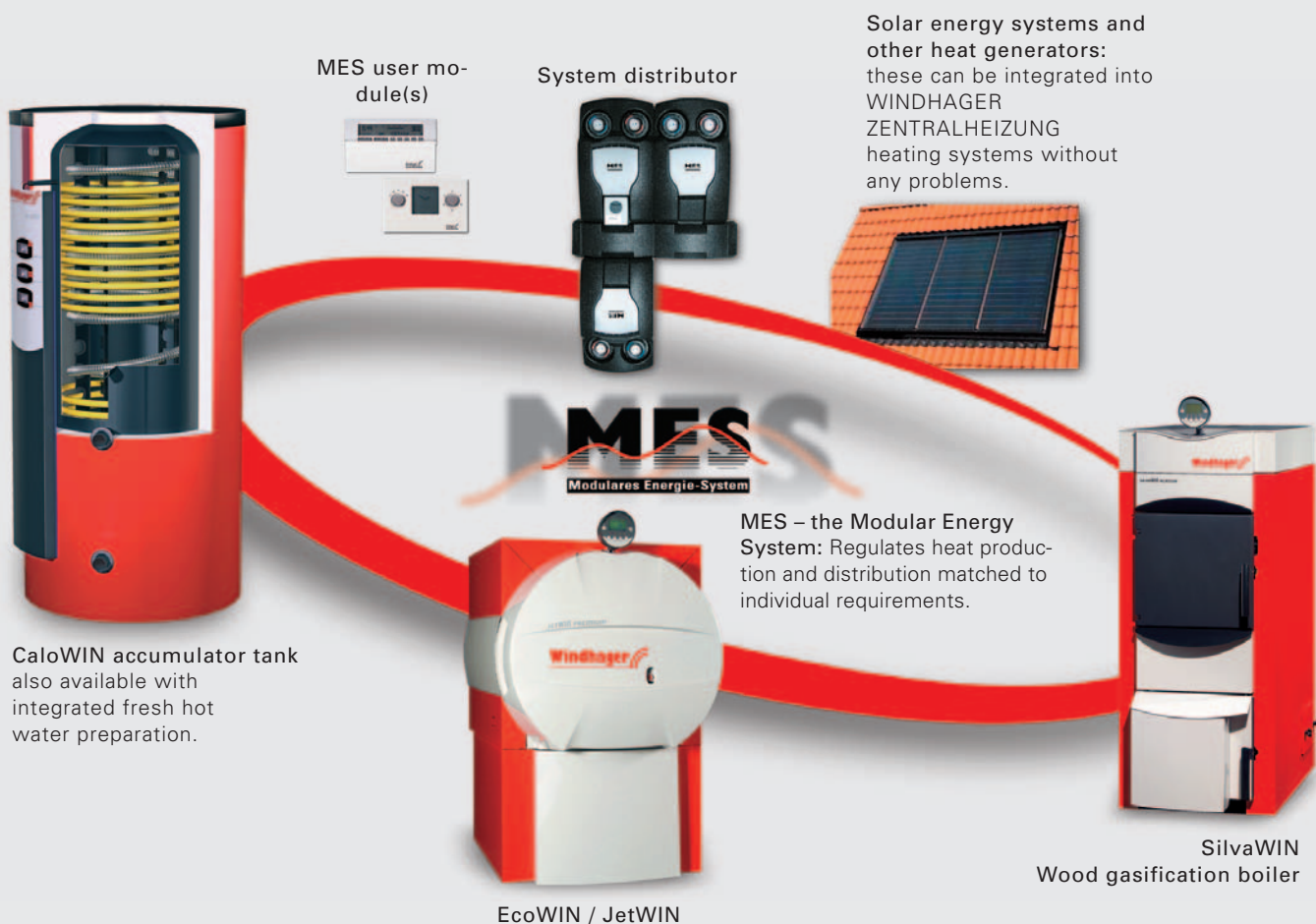

Convincing intrinsic values.

Technical data.

EcoWIN

EW (efficiency degree up to 103%)	Type	157	207	287
Nominal thermal output at $T_{feed}/T_{ret} = 80/60^{\circ}\text{C}$	kW	15	20	28
Water capacity	litres	61	61	62
Net weight	kg	125	125	130

JetWIN Exklusiv

JWE (efficiency degree up to 96%)	Type	165	225	305	365
Nominal thermal output range	kW	13.6 – 16.0	16.0 – 22.0	22.0 – 30.0	28.8 – 36.0
Water capacity	litres	75	97	112	112
Net weight	kg	135	180	190	190

For Switzerland

JWE (efficiency degree up to 96%)	Type	187	237	317	407
Nominal thermal output range	kW	13.6 – 18.0	18.0 – 23.0	22.0 – 31.0	30.0 – 40.0
Water capacity	litres	75	97	112	112
Net weight	kg	135	180	190	190

JetWIN Premium

JWP (efficiency degree up to 95%)	Type	155	205	285	455
Nominal thermal output range	kW	13.6 – 15.0	16.0 – 20.0	22.0 – 28.0	30.0 – 45.0
Water capacity	litres	58	75	97	112
Net weight	kg	110	135	180	190

JetWIN Klassik

JWK (efficiency degree up to 94%)	Type	175	215	275	365	455	555
Nominal thermal output range	kW	13.6 – 17.0	17.0 – 21.0	21.6 – 27.0	28.8 – 36.0	36.0 – 45.0	45.0 – 55.0
Water capacity	litres	58	58	75	97	112	112
Net weight	kg	120	120	135	180	215	215

For Switzerland

JWK (efficiency degree up to 94%)	Type	167	227	267	407
Nominal thermal output range	kW	13.6 – 16.0	16.0 – 22.0	21.0 – 26.5	27.0 – 40.0
Water capacity	litres	58	75	97	112
Net weight	kg	120	135	180	215



Dimensioned sketches (connections) for oil units on FKU, oil units on AquaWIN Kombi.

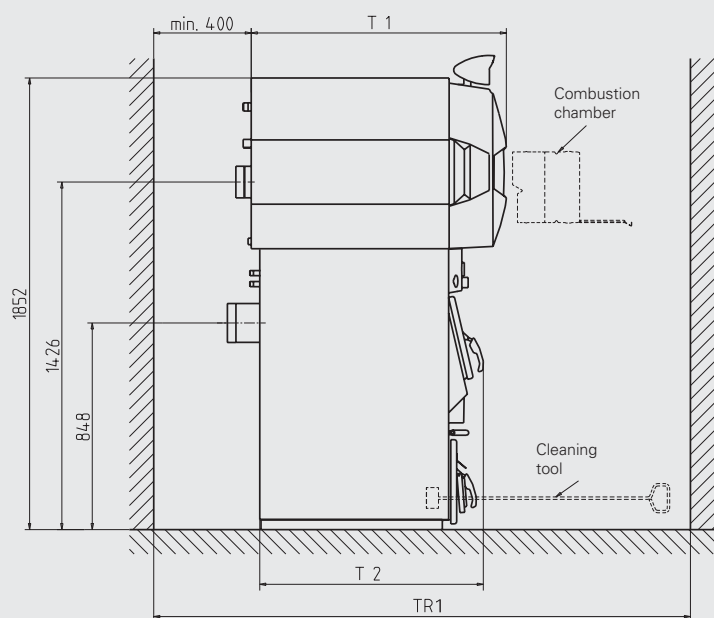

Oil units on FKU "boiler combination" – side view

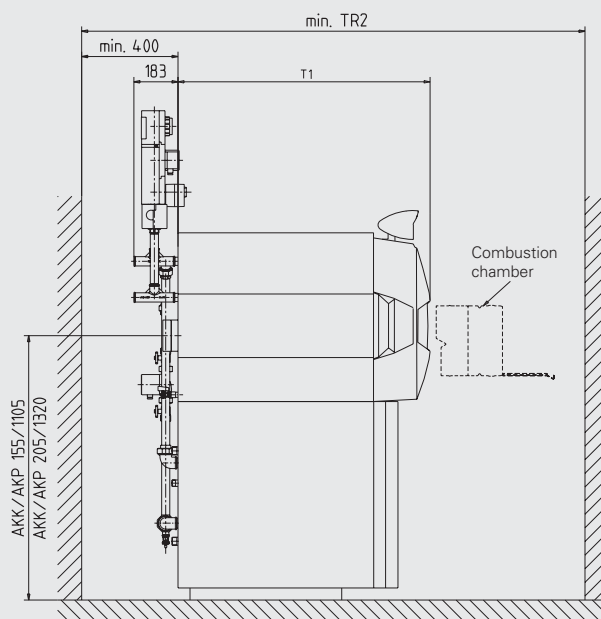

Oil units on water heater AquaWIN Kombi – side view

Combination with FKU

Oil units for EcoWIN / JetWIN	JWK 175/215 / JWP 155		JWE 165/JWP 205/JWK 275		EW 157 – 287	
	FKU 165/215	FKU 265/335	FKU 165/215	FKU 265/285	FKU 165/215	FKU 265/335
Depth of oil-fired unit T1	940	940	1050	1050	1235	1235
Depth of FKU T2	775	975	775	975	775	975
Room depth TR1	2350	2350	2350	2350	2720	2720

For Switzerland

Oil units for EcoWIN / JetWIN	JWK 167		JWE 187 / JWK 227		EW 157–287 / JWE 237 / JWK 267	
	FKU 165/225	FKU 265/335	FKU 165/225	FKU 265/335	FKU 165/225	FKU 265/335
Depth of oil-fired unit T1	940	940	1050	1050	1235	1235
Depth of FKU T2	775	975	775	975	775	975
Room depth TR1	2350	2350	2350	2350	2720	2720

Combination with AquaWIN

Oil units for EcoWIN / JetWIN	JWP 155	JWP 205, JWE 165/187	EW 157–287 / JWE 225/237
	JWK 167–215	JWK 227 / 275	JWP 285 / JWK 267/365
Depth of oil-fired unit T1	940	1050	1235
Room depth TR2	1940	2090	2490

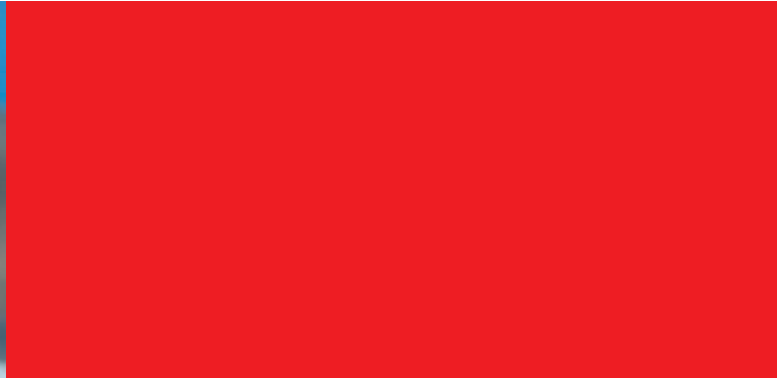

EcoWIN – dimensions

EcoWIN	Type	157	207	287
Height with cladding H (on stand)	mm	1152	1152	1152
Water return height R (on stand)	mm	880	880	880
Water flow height V (on stand)	mm	1030	1030	1030
Discharge E 1/2" IG	mm	480	480	480
Flue gas connection diameter	mm	80	80	80
Flow and return pipe connections	R"	1 AG	1 AG	1 AG

JetWIN Exklusiv – dimensions

JetWIN E	Type	165	225	305/365
JetWIN E, Switzerland	Type	187	237	317/407
Cladding depth T Cladding	mm	1050	1235	1410
Minimum room depth TR	mm	2090	2490	2790
Minimum clearance M	mm	880	1090	1090
Height with cladding H (on stand)	mm	1152	1152	1237
Water return height R (on stand)	mm	880	880	993
Water flow height V (on stand)	mm	1030	1030	1093
Discharge E 1/2" IG	mm	480	480	530
Flue gas connection diameter	mm	130	130	150
Flow and return pipe connections	R"	1 AG	1 AG	6/4 AG

JetWIN Premium – dimensions

JetWIN P	Type	155	205	285	455
Cladding depth T Cladding	mm	940	1050	1235	1410
Minimum room depth TR	mm	1940	2090	2490	2790
Minimum clearance M	mm	880	880	1090	1090
Height with cladding H (on stand)	mm	1152	1152	1152	1237
Water return height R (on stand)	mm	880	880	880	993
Water flow height V (on stand)	mm	1030	1030	1030	1093
Discharge E 1/2" IG	mm	480	480	480	530
Flue gas connection diameter	mm	130	130	130	150
Flow and return pipe connections	R"	1 AG	1 AG	1 AG	6/4 AG

JetWIN Klassik – dimensions

JetWIN K	Type	175	215	275	365	455	555
JetWIN K, Switzerland	Type	–	167	227	267	407	–
Cladding depth T Cladding	mm	940	940	1050	1235	1410	1410
Minimum room depth TR	mm	1940	1940	2090	2490	2790	2790
Minimum clearance M	mm	880	880	880	1090	1090	1090
Height with cladding H (on stand)	mm	1152	1152	1152	1152	1237	1237
Water return height R (on stand)	mm	880	880	880	880	993	993
Water flow height V (on stand)	mm	1030	1030	1030	1030	1093	1093
Discharge E 1/2" IG	mm	480	480	480	480	530	530
Flue gas connection diameter	mm	130	130	130	130	150	150
Flow and return pipe connections	R"	1 AG	1 AG	1 AG	1 AG	6/4 AG	6/4 AG

Windhager provides more than first-class products:

Quality consulting from our expert partners.

You can obtain WINDHAGER ZENTRALHEIZUNG products from our expert PARTNERS. Our partners are experienced heating specialists who work in close professional cooperation with WINDHAGER ZENTRALHEIZUNG to achieve the best results for our customers.

Professional customer service network.

Perfect customer service is one of the mainstays of WINDHAGER's success. Our professional customer service network guarantees the best customer care every day. Our customer service technicians are experienced, non-bureaucratic professionals who work quickly and reliably.



Unique guarantees.

Our full five-year guarantee provides you with the best possible security. This is because our unique full guarantee doesn't just cover material (excluding wear parts), it also includes the travel and labour costs of the customer service technicians. Not only that, but we also guarantee that we will continue to supply your device with spare parts for 15 years from the date of purchase.

Guarantee conditions for a full five-year guarantee:

- Documented start-up
- Documented maintenance in the second and fourth years of service



JetWIN Klassik



EcoWIN
JetWIN Premium/
Exklusiv



Your expert partner:

Austria (Headquarters/Production):

Windhager Zentralheizung AG
A-5201 Seekirchen near Salzburg
Anton-Windhager-Straße 20
Tel. +43 (0)6212/23 41-0
Fax +43 (0)6212/4228

Windhager Zentralheizung AG

A-1230 Vienna
Carlberggasse 39
Tel. +43 (0)1/869 4328
Fax +43 (0)1/865 13 81

e-mail info@windhager-ag.at

Germany:

Windhager Zentralheizung AG
D-86405 Meitingen near Augsburg
Deutzring 2
Tel. +49 (0)8271/80 56-0
Fax +49 (0)8271/80 56 -30

Windhager Zentralheizung GmbH

D-04509 Delitzsch near Leipzig
Heinrich-Rudolf-Hertz-Straße 2
Tel. +49 (0)34202/723-0
Fax +49 (0)34202/723-30

e-mail info@windhager-ag.de

Switzerland:

Windhager Zentralheizung Schweiz AG
CH-6203 Sempach-Station near Luzern
Industriestrasse 13
Tel. +41 (0)41/469 469-0
Fax +41 (0)41/469 469-9

e-mail info@windhager-ag.ch